

BullsEye Tag
ISO 15 693
NXP I-Code SLI
Sales code 3001423

Mechanical dimensions

A	Transponder coil diameter	33	[mm]	± 0,5	[mm]
B	Transponder die-cut diameter	40	[mm]	± 0,2	[mm]
C	Web width	48	[mm]	± 0,5	[mm]
D	Pitch, length per piece (MD)	48	[mm]	± 0,5	[mm]
E	Die-cut to web edge	4	[mm]	± 2	[mm]
F	Die-cut to register mark	2,5	[mm]	± 2	[mm]
G	Transponder coil to hole	8,5	[mm]	± 1,5	[mm]
H	Transponder coil to die-cut (CD)	3,5	[mm]	± 1,5	[mm]
I	Hole diameter	16	[mm]	± 0,2	[mm]
	Thickness of the IC	150	[µm]	± 10	[%]
	Overall thickness of transponder package (excluding IC and siliconized paper)	200	[µm]	± 10	[%]
	Thickness of the siliconized paper	56	[µm]	± 10	[%]

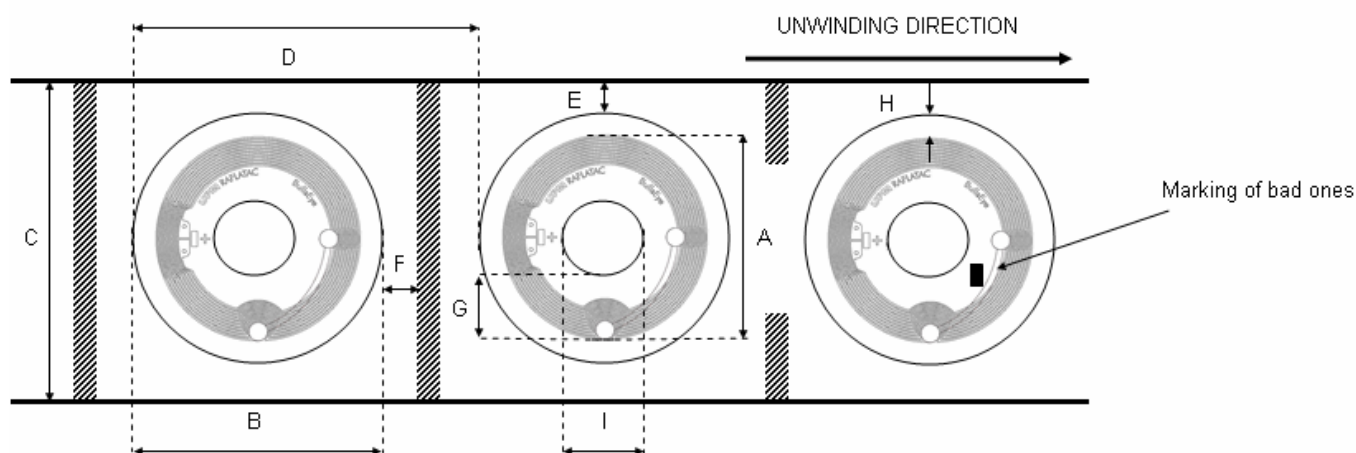

Electrical characteristics

Integrated Circuit (IC)	NXP I-Code SLI, SL2ICS20
IC's protocol / anti-collision	ISO 15693
Operating frequency	13,56 MHz
Unloaded resonance frequency	13,80 MHz ± 0,35 MHz
Memory	1k bit R/W EEPROM

General characteristics of transponder

Operating temperature (electronics parts)	-25°C/+85°C
ESD voltage immunity	+/- 2 kV peak, HBM
Shelf life	+20°C, 50 % RH, max 2 years
Bending diameter (D)	> 50 mm, tension less than 10 N
Static pressure (P)	< 10 MPa (10 N/mm ²)

Delivery form

Transponder format	Die-cut
Transponder face material	Opaque matt paper 79
Transponder backing material	Siliconized paper 56
Transponder adhesive	RA-4
- labeling temperature	min. +5°C
- usage temperature	min. -10°C- +90°C
- peel	min. 10 N/25mm (FTM 2)
Transponder antenna material	Aluminum
Final inspection	100% inspection, yield >95%. Known faulty ones marked.
Reel labeling	Reel number, material number, amount, prod. order number, yield and date
Printability	TTR with selected ribbons, do not print over IC area

Structure

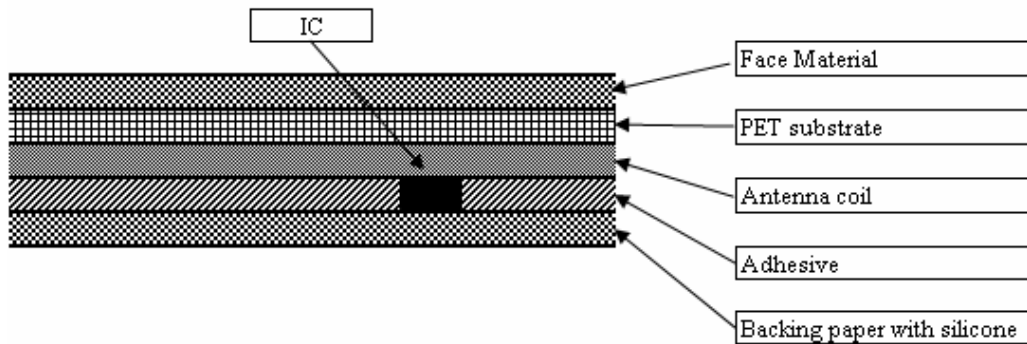

Delivery details

Appearance	Single-row reel form
Reel core	Paper core inner diameter 76 mm (3")
Transponder alignment	Chip at rear of transponder
Winding of the reel	Face out

Disclaimer:

UPM Raflatac reserves the right to change its products and services at any time without notice. Our recommendations are based on our best knowledge and experience. As the products are used outside our control we cannot take responsibility for any damage that may be caused when using the product.

This technical specification replaces all earlier ones.

Version 1.0
 Update date 10 June 2008
 Author UPM Raflatac, RFID / AnL
 Approved UPM Raflatac, RFID / KKe